

PARTS MANUAL

BEN PEARSON PIPE BENDERS

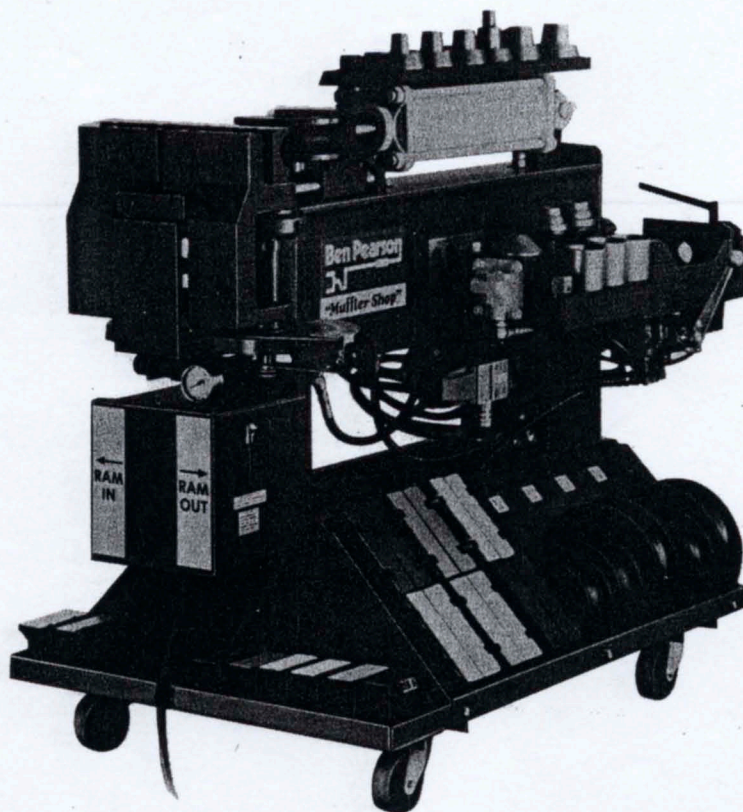

MC-59
MC-59HS

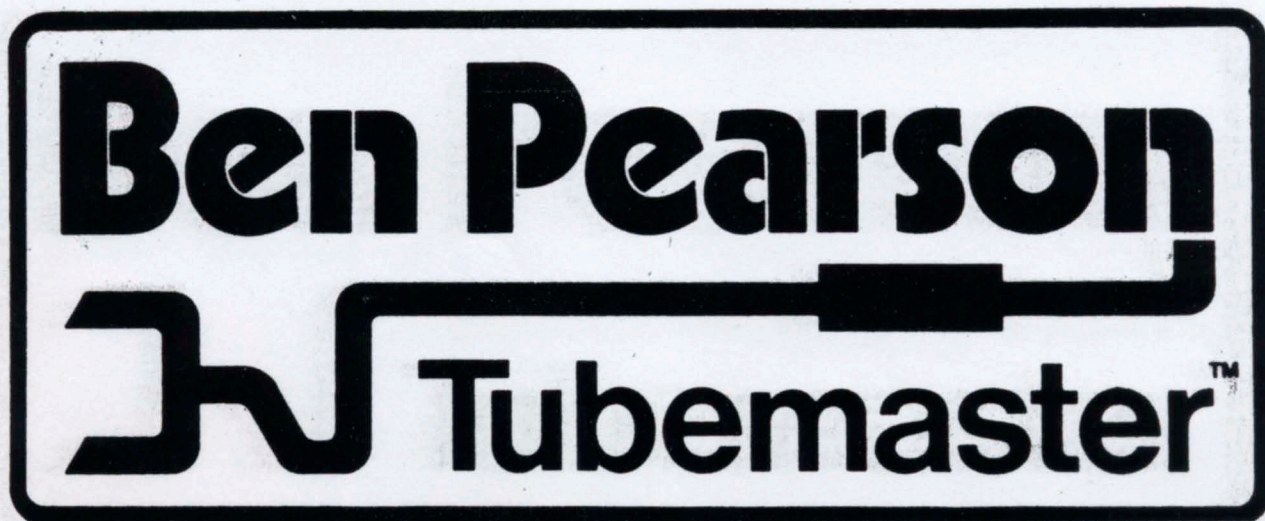

MAIN FRAME

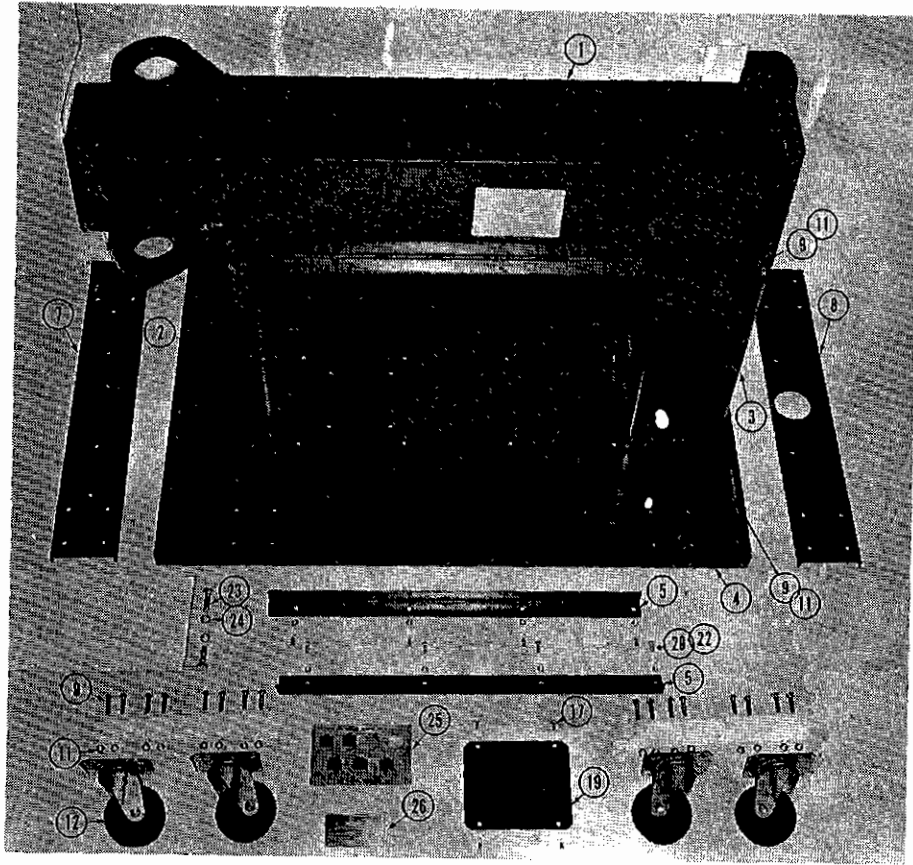

Code	Part Number	Part Name	Quantity		
			EXP 69	MC59	MC59 HS
1	62040	Main Frame Structure	1		
1	61341	Main Frame Structure		1	1
2	62018	Support Structure - Front	1		
2	61368	Support Structure - Front		1	
2	61697	Support Assembly Front			1
3	62057	Tank Structure - Hydraulic	1		
3	61351	Tank Structure - Hydraulic		1	
3	61889	Tank Structure - Hydraulic			1
4	62017	Base - Tray	1		
4	60615	Base - Tray		1	
4	61612	Base - Tray			1
5	60616	Die Stop (Tray)	2	2	
7	60173	Bottom Support - Front	1	1	1
8	60618	Bottom Support - Rear	1	1	1
9	100238	HFHSL Screw	28	28	28
11	100239	HFHSL Nut	28	28	28
12	60089	Swivel Caster	4	4	4
17	100076	Screw - Thread Cutting	8	8	8
19	61357	Cover	2	2	2
20	100234	HFHSL Screw	8	8	
22	100237	HFHSL Nut	8	8	
23	100180	Hex Screw (Die Stop) Full Thd.	2	2	2
24	100178	Jam Nut	2	2	2
25	60297	Color Chart - For Selecting Dies	2	2	2
26	62249	Name Plate	1	1	
26	62255	Name Plate			1
#	61789	Decal "BEN PEARSON TUBEMASTER"	1	1	1
#	61653	Decal "HI-SPEED"			1
#	61356	Fill Cap-Oil Reservoir	1	1	
#	61884	Fill Cap-Oil Reservoir			1
#	61897	Air Vent			1
#	60747	Bushing - Pivot Arm Shaft (Replacement - Main Frame)	4	4	4
#	61553	Grease Fitting - Main Frame	4	4	4
#		NOT SHOWN			

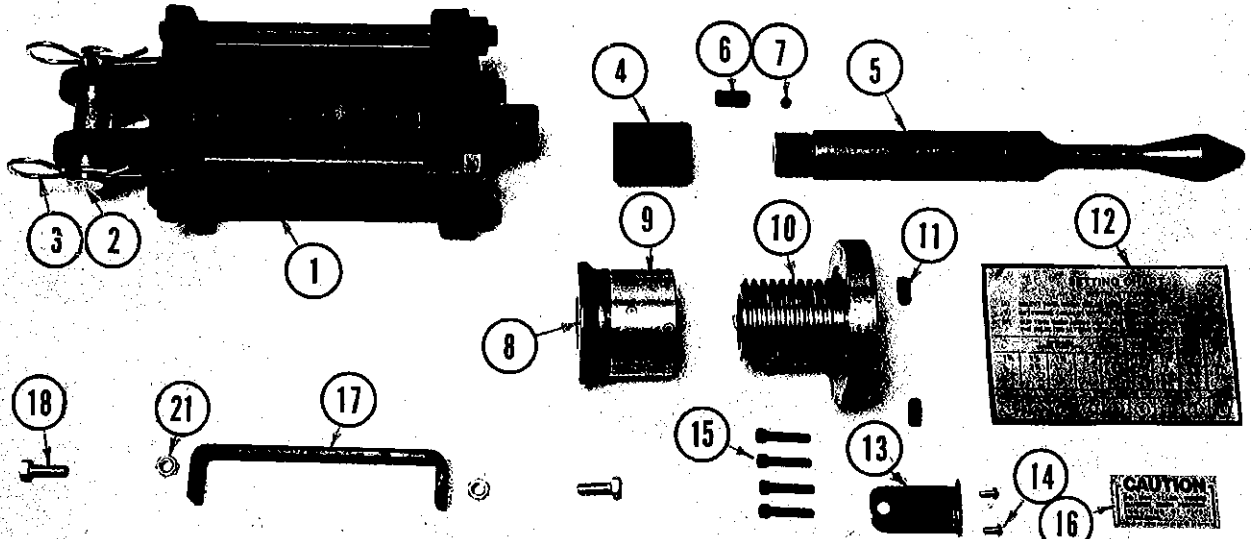

Code	Part Number	Part Name	Quantity	
			MC59	MC59 HS
1	61290	Cylinder - Expander 4-Bore - 4 Stroke - 1 1/2 Rod	1	1
2	60436	Pin (Included in Cylinder)	1	1
3	100110	Quick Pin (Included in Cylinder)	2	2
4	60278	Coupler	1	1
-	60356	Arbor Bolt Assembly (Large) Consists Of:	1	1
5		1 - 60284 Arbor Bolt (Large)		
6		1 - 60355 Soc. Hd. Set Screw 1/2-13 NC x 1		
7		1 - 100015 Soc. Hd. Set Screw 5/16-18NC x 1/4		
-	61500	Adjustment Nut & Bolt Kit Consists Of:	1	1
8		1 - 61216 Adjusting Nut Structure		
9		1 - 61780 Decal - Acme Nut Setting		
10		1 - 61394 Adjustment Bolt w/Adapter Assembly Includes:		
11		2 - 100052 Soc. Hd. Set Screw 3/8-16 NC x 3/4		
12		1 - 61779 Decal - "SETTING CHART"		
13		1 - 61397 Sight Gauge		
14		2 - 100108 Round Hd. Machine Screw #10-24 NC x 3/8		
15	100193	Soc. Hd. Cap Screw 1/4-28 NF x 1 1/4	4	4
16	60653	Decal - "CAUTION"	1	1
17	60160	Rest - Cylinder	1	1
18	100238	HFHSL Screw 3/8-16NC x 1 Gr. 5	2	2
21	100239	HFHSL Nut 3/8-16NC	2	2
#	61492	Seal Kit (Replacement - Prince Cyl.)	1	1
#	61877	Seal Kit (Replacement - Cross Cyl.)	1	1
#		NOT SHOWN		
#		OPTIONAL		
#	61261	Arbor Bolt Assembly (Small) Consists Of:	1	1
		1 - 61262 Arbor Bolt (Small)		
		1 - 60355 Soc. Hd. Set Screw 1/2-13 NC x 1		
		1 - 100015 Soc. Hd. Set Screw 5/16-18 NC x 1/4		
#	61865	Kit - To Replace 60603 Adj. Nut & Bolt	1	1

HYDRAULIC VALVES AND GAUGES

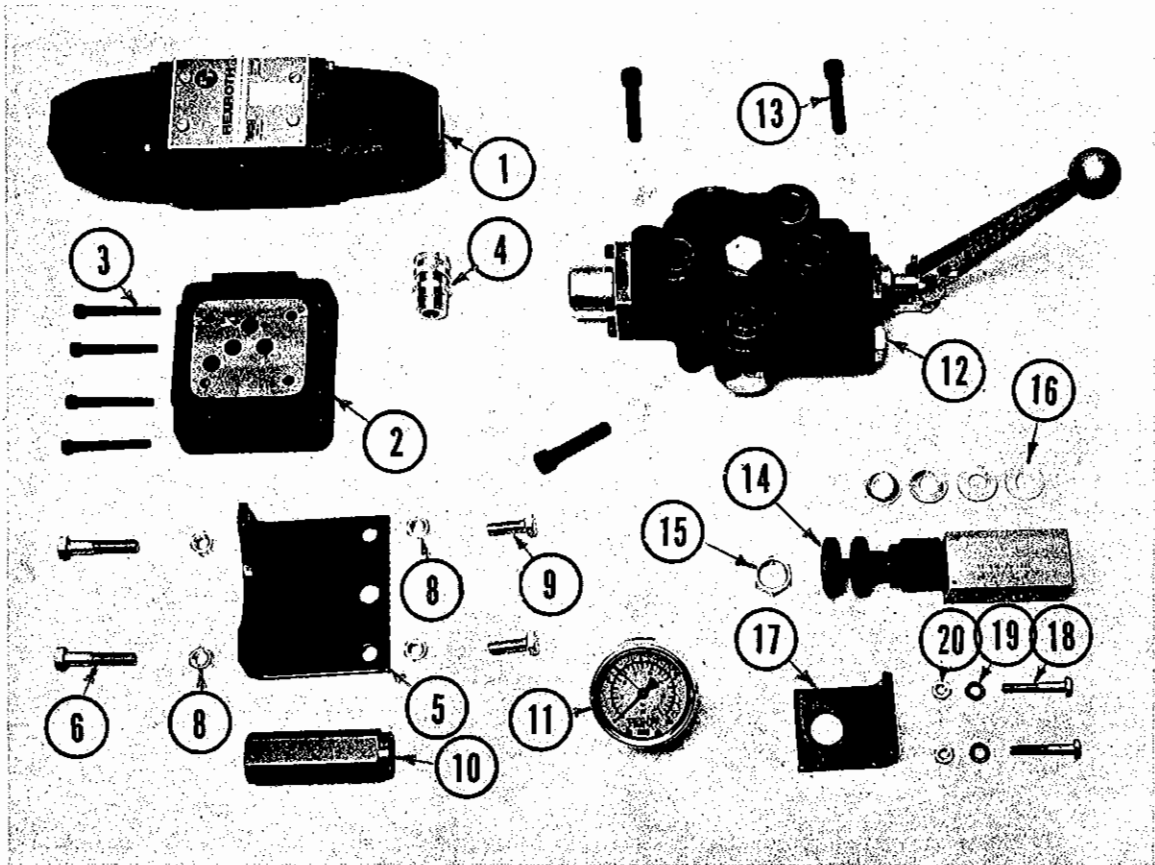

Code	Part Number	Part Name	Quantity	
			MC59	MC59 HS
		CONTROL VALVE - STARTING w/Serial No. M14477S		
1	61950	Control Valve - Directional	1	1
2	61330	Subplate - Valve	1	1
3	100312	Socket Head Cap Screw 1/4 - 20 NC x 2 1/2	4	4
#	61836	Lock Washer - High Collar 1/4	4	4
4	61101	Strain Relief Bushing	1	1
5	61358	Angle - Valve Support	1	1
6	100028	Hex Screw 3/8-16NC x 1 3/4 Gr. 5	2	2
8	100239	HFHSL Nut 3/8-16NC	4	4
9	100238	HFHSL Screw 3/8-16NC x 1 Gr. 5	4	4
10	61328	Check Valve	1	1
11	60085	Pressure Gauge 1/4 NPT Stem	1	1
12	61299	Manual Control Valve (See Breakdown - Cross)	1	1
12	62169	Manual Control Valve (See Breakdown - Prince)	1	1
13	60990	Socket Head Cap Screw 3/8-16NC x 1 3/4	3	3
14	61298	Relief Valve	1	1
15	60058	Bulkhead Nut 3/4 - 16 Thd. 37° JIC	1	1
16	100164	Flat Washer (As Required to Set Relief Valve Pressure Max. 1200 PSI)	4/5	4/5
17	61349	Angle - Relief Valve Mount	1	1
18	100059	Hex Screw 1/4 - 20 NC x 1 3/4	2	2
19	100134	Lock Washer 1/4	2	2
20	100131	Hex Nut 1/4 - 20 NC	2	2
#	62174	Solenoid (For Valve #61950) PARKER HANIFIN	2	2
#	62175	Coil for Valve - Parker Hanifin (Replacement Only)	2	2
#	62256	Coil for Replacement - Vickers	2	2
#		NOT SHOWN		

VALVES & GAUGES EXP 69

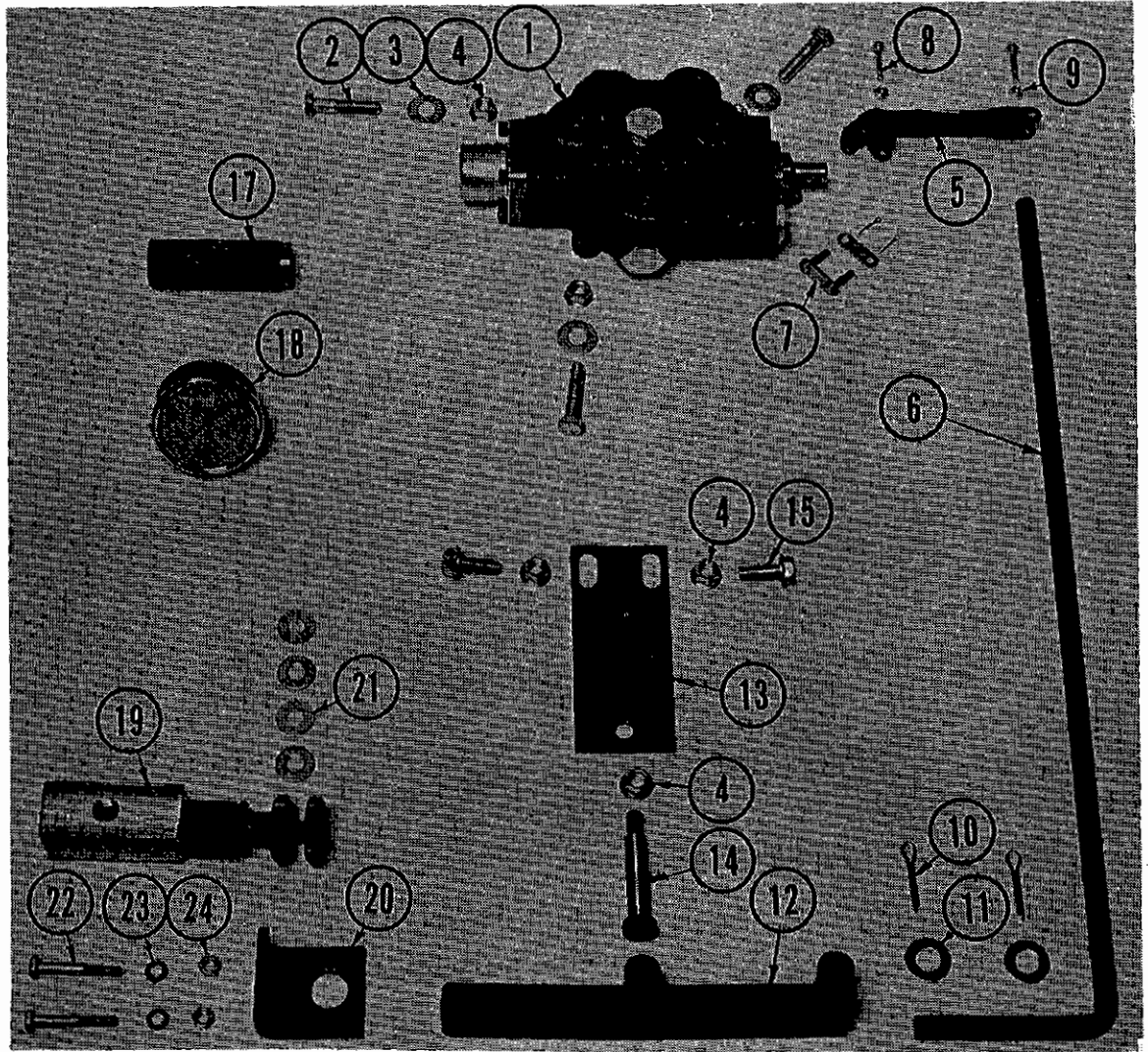

Code	Part Number	Part Name	Quantity	
			EXP	69
1	62170	Valve - Manual - Prince	1	
1	62007	Valve - Manual - Cross (See Breakdown 9/16-18 ORB Ports)	1	
2	100028	Hex Screw 3/8-16NC x 1 3/4 (Mt. 62007)	3	
3	100082	Flat Washer (Spacer) (Mt. 62007)	3	
4	100239	HFHSL Nut 3/8-16NC (Mt. 62007)	6	
5	62020	Handle Structure (Cross)	1	
5	62164	Handle Structure (Prince)	1	
6	62028	Rod - Pull	1	
7	60431	Pin Kit (Comes w/62007 Cross Valve)	1	
8	100251	Hex Machine Screw #10-24NC x 1	2	
9	100252	Nylock Nut #10-24NC	2	
10	100248	Cotter Pin 3/16 x 1 (Rod to Pedal)	2	
11	100062	Flat Washer 33/64 ID - .06 Thick	2	
12	62024	Foot Pedal Structure	1	
13	62027	Support - Pivot	1	
14	100247	Shoulder Screw 3/8-16 Thd. (Pedal-Support)	1	
15	100238	HFHSL Screw 3/8-16NC x 1 (Support - Base)	2	
17	61328	Check Valve	1	
18	60085	Pressure Gauge	1	
19	61298	Relief Valve	1	
20	61349	Angle - Relief Valve Mount	1	
21	100164	Flat Washer (Relief Valve Pressure)	4	
22	100059	Hex Screw 1/4-20 NC x 1 3/4	2	
23	100134	Lockwasher 1/4	2	
24	100131	Hex Nut 1/4 20 NC	2	

**CONTROL VALVE - CROSS
BREAKDOWN**

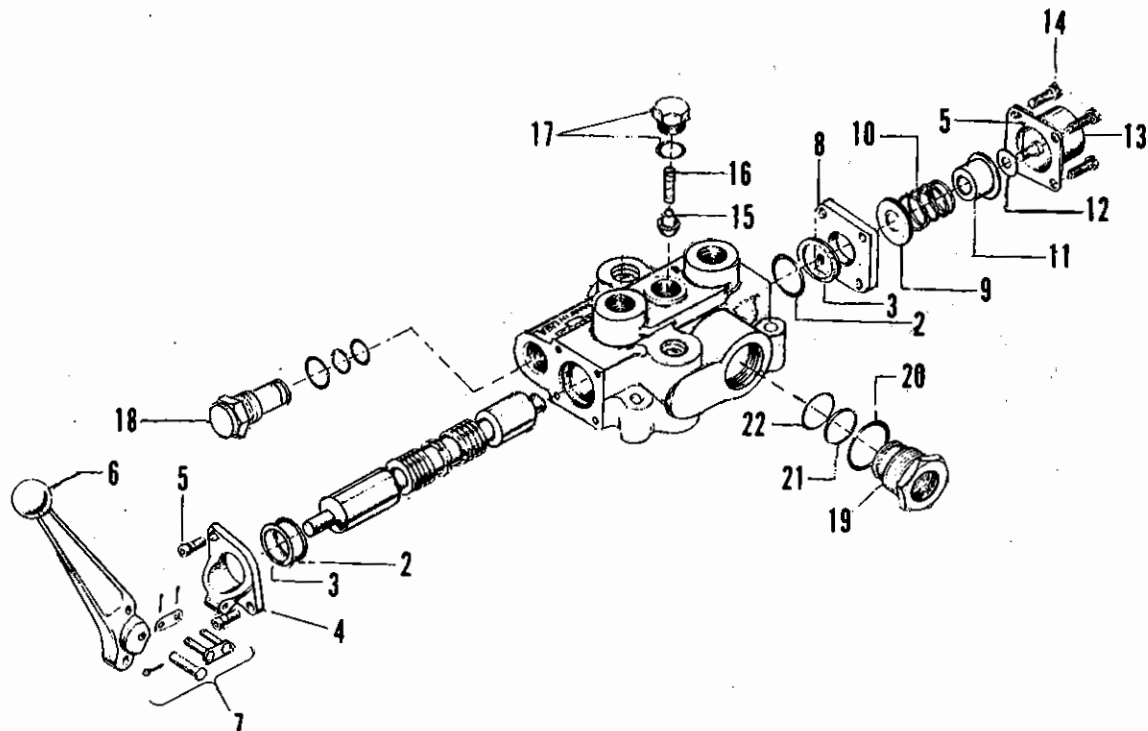

Code	Part Number	Part Name	Quantity		
			EXP 69	MC59	MC59 HS
	61299	Control Valve - Hydraulic (Cross Valve)	1	2	2
		Consists OF:			
2		2 - 60483 Spool Seal			
3		2 - 60484 O'Ring Spool Washer			
4		1 - 60485 Handle Bracket			
5		3 - 60486 Machine Screw			
6		1 - 60432 Handle			
7		1 - 60431 Pin Kit - Handle			
8		1 - 60487 End Spacer			
9		1 - 60488 Stop Washer			
10		1 - 60489 Centering Spring			
11		1 - 60490 Stop Collar			
12		1 - 60491 Centering Spring Washer			
13		1 - 60492 End Cap			
14		4 - 60493 Machine Screw			
15		1 - 60494 Load Check Poppet			
16		1 - 60495 Load Check Spring			
17		1 - 60496 Load Check Plug Assembly			
18		1 - 60497 Relief Plug Assembly			
19		1 - 61385 Power Beyond Sleeve			
20		1 - 60499 Plug O'Ring			
21		1 - 60600 O'Ring Back-up			
22		1 - 60601 O'Ring			

CONTROL VALVE - PRINCE BREAKDOWN

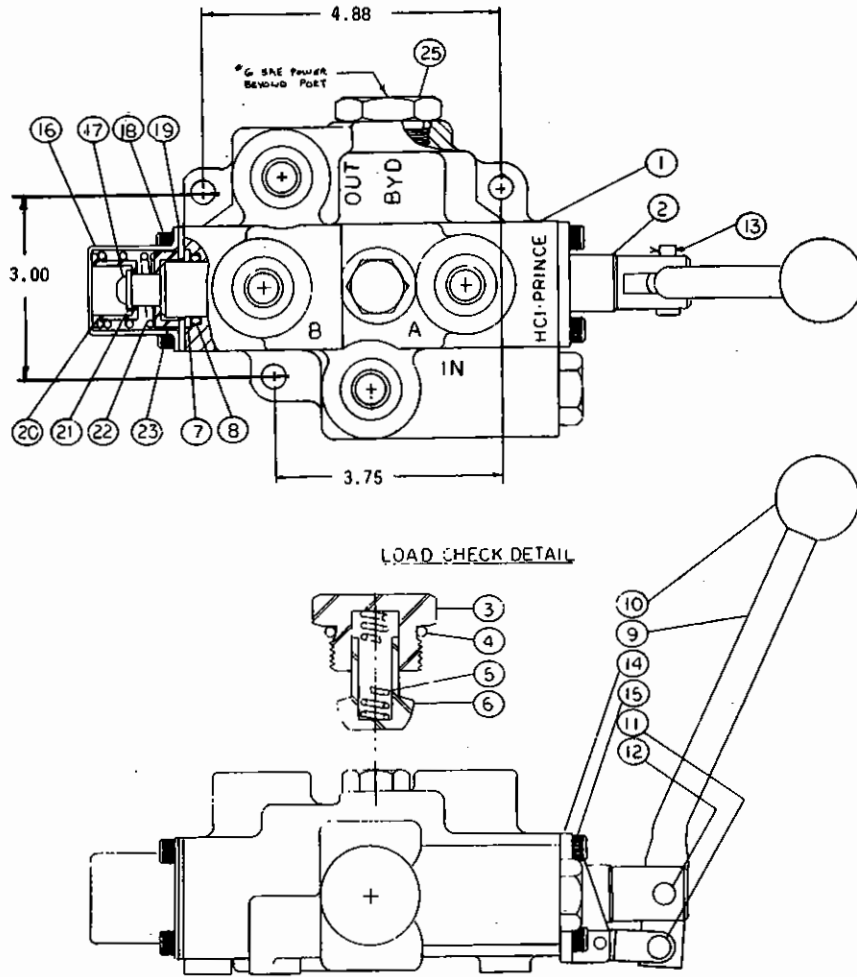

Code	Part Number	Part Name	Quantity		
			EXP 69	MCS9	MCS9
-	62169	Control Valve - Hydraulic (Prince Valve)	1	2	2
		Consists Of:			
1	1 -	Machined Body			
2	1 -	Spool			
3	1 -	Load Check Plug			
4	1*-	O'Ring			
5	1 -	Load Check Spring			
6	1 -	Load Check Poppet			
7	2 -	Spool Back-Up Ring			
8	2*-	Spool O'Ring Seal			
9	1 - 62171	Handle			
10	1 - 62172	Knob			
11	1 - 62098	Clevis Pin			
12	1 - 62099	Clevis Pin			
13	2 - 100185	Cotter Pin 1/16 x 1/2			
14	1 - 62090	Clevis Sub-Ass'y			
15	4 - 62173	Cap Screw			
16	1 -	Spring End Cap			
17	1 -	Cap Screw			
18	4 -	Cap Screw			
19	1 -	Retainer Plate			
20	1 -	Stop Cup (Outer)			
21	1 -	Washer			
22	1 -	Spring			
23	1 -	Stop Cup (Inner)			
24	1 -	No Relief Plug			
25	1 -	Power Beyond Plug			
#	61984	* Packing Kit	1	1	1

CLAMP DOWN SWAGER

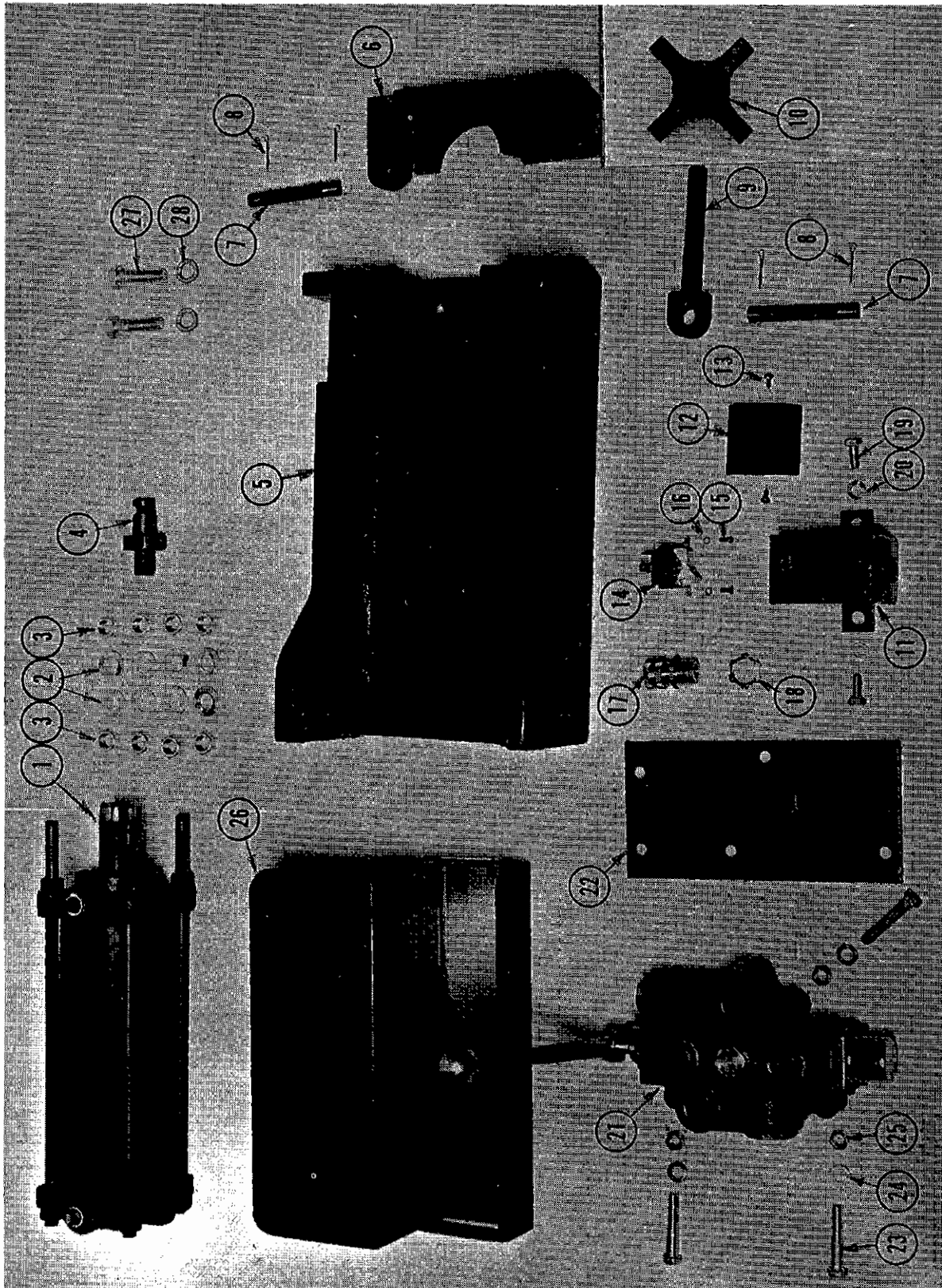

CLAMP DOWN SWAGER

PAGE 1

Code	Part Number	Part Name	Quantity		
			MC59	MC59	HS
1	61288	Hydraulic Cylinder 3 1/2 Bore - 7 Stroke 1 1/4 Rod	1	1	
2	61842	Flat Washer Cross Cylinder	8	8	
2	100141	Flat Washer Prince Cylinder	8	8	
3	100063	Hex Nut 9/16-18NC (Cross Cyl.)	8	8	
4	61247	Cylinder Adapter	1	1	
#	61515	Vice Assembly Consists Of:	1	1	
5		1 - 61440 Vise & Base Structure			
6		1 - 61419 Vise Structure - Top			
7		2 - 61443 Pin - Pivot			
8		4 - 100189 Cotter Pin 3/32 x 1			
9		1 - 61760 Clamp Bolt			
10		1 - 61597 Knob 5/8-11NC			
11	61095	Switch Box Structure	1	1	
12	60830	Switch Box Back Cover	1	1	
13	100091	Self Tapping Screw #10-24NC x 1/2	2	2	
14	60423	Power Switch (See Electric Diagram)	1	1	
15	60263	Round Head Machine Screw #6-32NC x 3/8	2	2	
16	60269	Lock Washer #6	2	2	
17	61101	Strain Relief Bushing (Switch Box)	1	1	
18	61102	Conduit Lock Nut 1/2 NPT	1	1	
19	100002	Hex Screw 5/16-18NC x 3/4 Gr. 5	2	2	
20	100159	Lock Washer 5/16	2	2	
21	61299	Valve (See Breakdown - Cross)	1	1	
21	62169	Valve (See Breakdown - Prince)	1	1	
22	61359	Valve Mount	1		
22	61623	Valve Mount		1	
23	100130	Hex Screw 3/8-16NC x 2	3	3	
24	100119	Lock Washer 3/8	3	3	
25	100127	Hex Nut 3/8-16NC	3	3	
26	60885	Tool Tray Structure (Auxiliary)	1	1	
27	80453	Hex Screw (Vise to Frame) 1/2-13NC x 1 3/4 Gr. 5	2	2	
28	100125	Lock Washer (Vise to Frame) 1/2	2	2	
#	60925	Seal Kit (For Cross Cylinder)	1	1	
#	61800	Decal "CAUTION"	1	1	
#	62000	Rod - Cylinder (For Cross Cylinder)	1	1	
#	62163	Switch Box Ass'y. (Includes 11-14-15-16-17-18)	1	1	
		REFERENCE:			
		60971 Solid Die Swaging Kit			
#		NOT SHOWN			

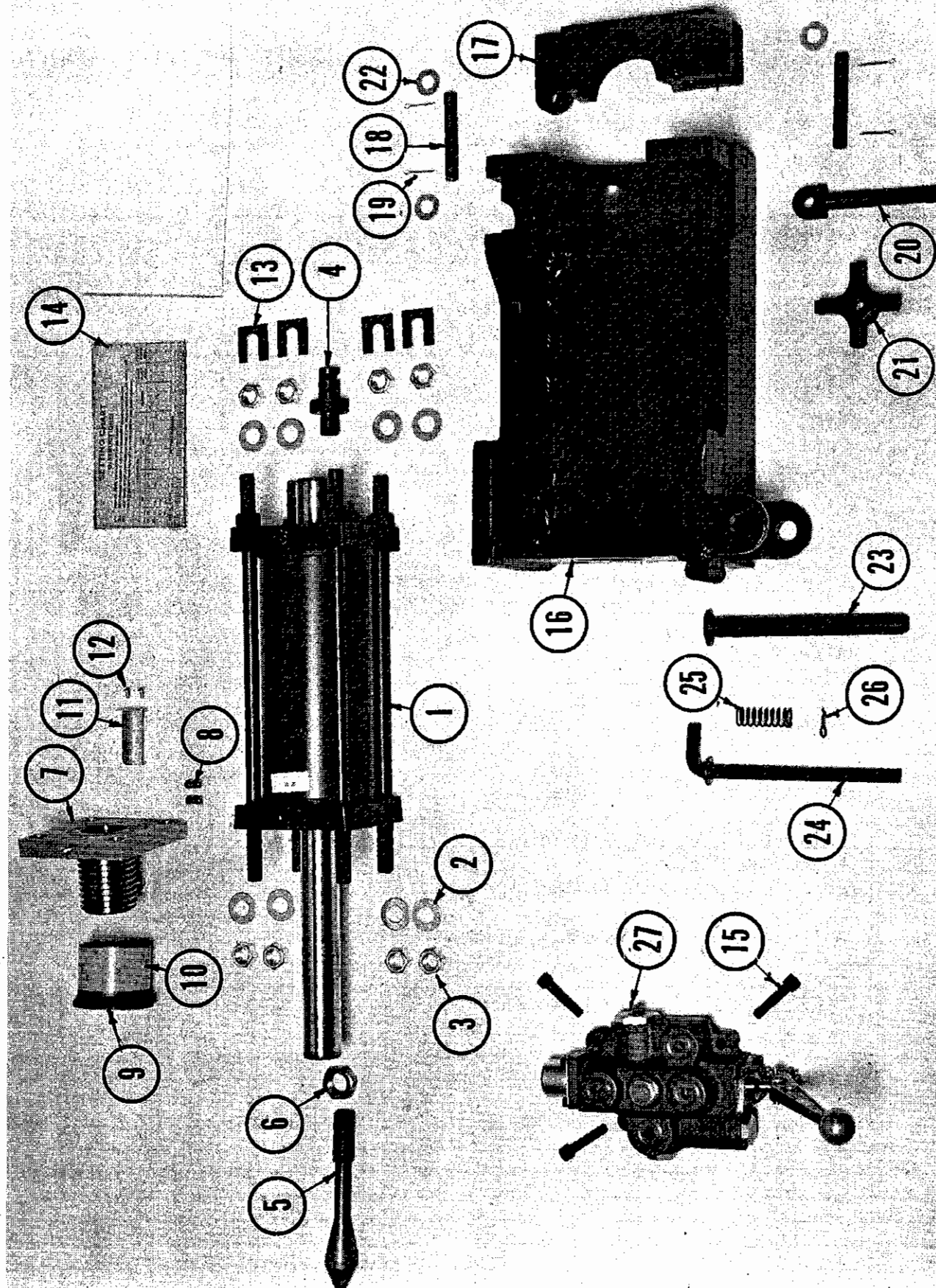

Code	Part Number	Part Name	Quantity		
			EXP	69	
1	62029	Hdy. Cylinder (Swager & Expander) 7" Stroke - 1 1/2 Rod	1		
2	100155	Flat Washer 21/32 ID 1 5/16 OD - 13 Ga	8		
3	100073	Hex Nut 5/8-18 NF	8		
4	61247	Adapter - Cylinder	1		
5	62059	Arbor Bolt	1		
6	100266	Hex Jam Nut 7/8-14 NF	1		
7	62060	Adjustment Bolt w/Adapter Ass'y	1		
8	100052	Socket Hd. Set Screw 3/8-16 NC x 3/4	2		
9	62062	Adjustment Nut Structure	1		
10	61780	Decal - ACME NUT SETTING	1		
11	61397	Sight Gauge	1		
12	100108	Rd. Hd. Machine Screw #10-24NC x 3/8	2		
13	62067	Shim .060	4		
14	61779	Decal - SETTING CHART	1		
15	60990	Socket Head Cap Screw 3/8-16NC x 1 3/4	3		
#	62056	Vise Assembly Consists Of:	1		
16		1 - 62044 Vise & Base Structure			
17		1 - 61419 Vise Top Structure			
18		2 - 61443 Pin			
19		4 - 100189 Cotter Pin			
20		1 - 61760 Clamp Pivot (Bolt)			
21		1 - 61597 Hand Knob - Threaded			
22		3 - 100141 Flat Washer 17/32 ID			
23	62068	Pin Structure - Vise	1		
24	62070	Rod Structure	1		
25	81530	Spring	1		
26	100175	Cotter Pin	1		
27	61299	Valve - Manual (Cross only) See Breakdown	1		
27	62169	Valve - Manual (Prince only) See Breakdown	1		
#	100119	Lock Washer 3/8	3		
#	62039	Seal Kit (Prince Cylinder)	1		
#	62183	Piston Rod (Prince Cylinder)	1		
#	60653	Decal - CAUTION	1		

HYDRAULIC DIAGRAM MODELS MC59

61874

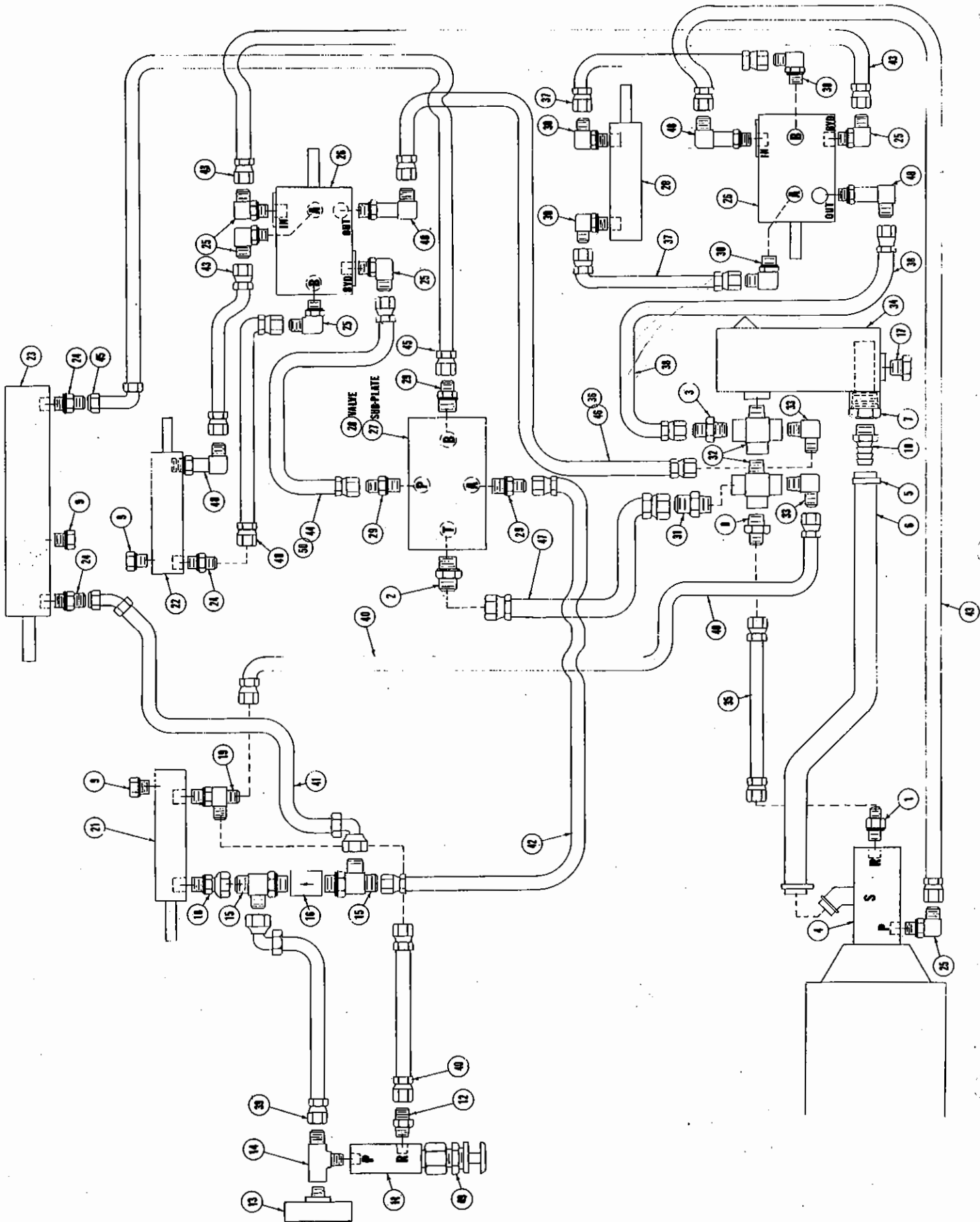

HYDRAULICS FOR MODELS MC59

PAGE 19

Code	Part Number	Part Name	Quantity		
1	61512	Adapter - Straight	1/2-20 ORB to 7/16-20 JIC	1	
2	100069	Male Connector	3/4-16 ORB to 3/4-16JIC	1	
3	60061	Male Connector	9/16-18JIC to 1/2 NPT	1	
4	60428	Pump Ass'y.	(Barnes & MTE)	1	
5	100123	Hose Clamp		2	
6	60074	Hose-Suction	3/4 ID - 36 Long	1	
7	61331	Suction Strainer	3/4 NPT Female - 1 1/4 NPT	1	
8	61557	Male Connector	7/16-20 JIC - 1/2 NPT	1	
9	100026	Hex Plug (Replacement)	9/16 - 18 ORB	3	
10	100139	Hose Barb - Male	3/4 NPT to 3/4 ID Hole	1	
11	61298	Relief Valve	1/4 NPT Ports	1	
12	100037	Male Connector	1/4 NPT to 9/16 - 18 JIC	1	
13	60085	Pressure Gauge	1/4 NPT Stem	1	
14	61295	Female Run Tee	1/4 NPT (2) - 9/16-18 JIC Run	1	
15	61293	Male Run Tee	3/4-16 JIC (2)-3/4-16 ORB Run	2	
16	61328	Check Valve	3/4-16 ORB Ports	1	
17	100117	Pipe Plug	1/2 NPT	1	
18	61327	Swivel Reducer	9/16-18 ORB x 3/4-16 JIC	1	
19	61294	Male Run Tee	9/16-18 ORB x 9/16 JIC (2)	1	
20	61288	Hydraulic Cylinder (Swager)	9/16-18 ORB Ports	1	
21	61289	Hydraulic Cylinder (Back Pressure)	9/16-18 ORB Ports	1	
22	61290	Hydraulic Cylinder (Expander)	9/16-18 ORB Ports	1	
23	61291	Hydraulic Cylinder (Main)	9/16-18 ORB Ports	1	
24	60544	Male Connector	9/16-18 ORB to 9/16-18 JIC	3	
25	60368	90° Elbow	9/16-18 ORB to 9/16-18 JIC	6	
26	61299	Valve (Cross) (Prince)	9/16-18 ORB Ports	2	
27	61330	Sub-Plate - Control Valve	3/4-16 ORB Ports	1	
28#	61950	Control Valve - Directional		1	
29	61326	Male Connector	3/4-16 ORB to 9/16-18 JIC	3	
30	61296	90° Elbow	9/16-18 ORB to 7/16-20 JIC	4	
31	100043	Male Connector	3/4-16 JIC to 1/2 NPT	1	
32	61329	Pipe Cross	1/2 NPT (1-Male - 3 Female)	2	
33	60053	90° Elbow - Male	1/2 NPT to 9/16-18 JIC	2	
34	61351	Oil Reservoir Str.		1	
35	61558	Hose Assembly	1/4 ID 23 Long	1	
36	61982	Hose Assembly (Prince Val.)	3/8 ID 11.5 Long	1	
37	60735	Hose Assembly	1/4 ID 19 Long	2	
38	60070	Hose Assembly	3/8 ID 15 3/8 Long	1	
39	61881	Hose Assembly	3/8 ID 11 1/4 Long	1	
40	60547	Hose Assembly	3/8 ID 19 1/2 Long	3	
41	61882	Hose Assembly	3/8 ID 27 1/16 Long	1	
42	61883	Hose Assembly	3/8 ID 18 1/2 Long	1	
43	61484	Hose Assembly	3/8 ID 24 3/4 Long	3	
44	61483	Hose Assembly Cross Val.	3/8 ID 21 3/4 Long	1	
45	61485	Hose Assembly	3/8 ID 26 9/16 Long	1	
46	61482	Hose Assembly Cross Val.	3/8 ID 13 3/4 Long	1	
47	61486	Hose Assembly	1/2 ID 21 1/4 ID	1	
48	61362	90° Long Elbow	9/16-18 ORB to 9/16-18 JIC	4	
49	60058	Bulkhead Nut	3/4-16JIC	1	
50	61981	Hose Assembly (Prince Val.)	3/8 ID 23.5 Long	1	
#	62088	Kit - Test Pressure		1	

HYDRAULICS - MODELS MC59HS

Code	Part Number	Part Name	Quantity Required Per Model						
			MC59- HS						
2	60547	Hose Assembly	3/8 ID - 19 1/2 Long	1					
3	62001	Hose Assembly	3/8 ID - 18 1/4 Long	0					
4	62002	Hose Assembly	3/8 ID - 27 1/4 Long	0					
5	100123	Hose Clamp		2					
6	61895	Hose - Suction	1 ID - 36 Long	1					
7	61893	Suction Strainer	1" NPT Female - 1 1/2" NPT	1					
8	61361	90° Elbow Male	7/16-20 JIC - 3/8 NPT	1					
9	100026	Hex Plug (Replacement)	9/16-18 ORB	3					
10	60312	Hex Bushing	3/8NPT to 1/2 NPT	1					
11	61298	Relief Valve	1/4 NPT Ports	1					
12	100037	Male Connector	1/4 NPT to 9/16-18JIC	1					
13	60085	Pressure Gauge	1/4 NPT Stem	1					
14	61295	Female Run Tee	1/4NPT (2) - 9/16-18JIC Run	1					
15	61293	Male Run Tee	3/4-16JIC (2) - 3/4-16 ORB Run	2					
16	61328	Check Valve	3/4-16 ORB Ports	1					
17	100117	Pipe Plug	1/2 NPT	1					
18	61327	Swivel Reducer	9/16-18 ORB x 3/4-16 JIC	1					
19	61294	Male Run Tee	9/16-18 ORB x 9/16 JIC (2)	1					
20	61288	Hydraulic Cyl. (Swager)	9/16-18 ORB Ports	1					
21	61289	Hydraulic Cyl. (Back Pressure)	9/16-18 ORB Ports	1					
22	61290	Hydraulic Cyl. (Expander)	9/16-18 ORB Ports	1					
23	61291	Hydraulic Cyl. (Main)	9/16-18 ORB Ports	1					
24	60544	Male Connector	9/16-18 ORB to 9/16-18JIC	3					
25	60368	90° Elbow - Male	9/16-18 ORB to 9/16-18JIC	2					
26	61299	Valve (Cross)	9/16-18 ORB Ports	2					
27	61330	Sub-Plate - Control Valve	3/4-16 ORB Ports	1					
28#	61950	Control Valve Directional		1					
29	61326	Male Connector	3/4-16 ORB to 9/16-18JIC	2					
30	61296	90° Elbow	9/16-18 ORB to 7/16-20JIC	5					
31	100043	Male Connector	3/4-16JIC to 1/2 NPT	1					
32	61329	Pipe Cross	1/2 NPT (1 Male - 3 Female)	3					
33	60053	90° Elbow - Male	1/2NPT to 9/16-18JIC	4					
34	61889	Oil Reservoir Structure		1					
35	61487	Hose Assembly	1/4ID - 15 1/8 Long	1					
36	60734	Hose Assembly	1/4ID - 24 Long	1					
37	61656	Hose Assembly	1/4ID - 12 7/8 Long	1					
38	61704	Hose Assembly	3/8ID - 17 3/4 Long	1					
39	61881	Hose Assembly	3/8ID - 11 1/4 Long	1					
40	60547	Hose Assembly	3/8ID - 19 1/2 Long	2					
41	61882	Hose Assembly	3/8ID - 27 1/16 Long	1					
42	61883	Hose Assembly	3/8ID - 18 1/2 Long	1					
44	61625	Hose Assembly	1/2ID - 21 3/4 Long	1					
45	61485	Hose Assembly	3/8ID - 26 9/16 Long	1					
46	61482	Hose Assembly	3/8ID - 13 3/4 Long	1					
47	61486	Hose Assembly	1/2ID - 21 1/4 Long	1					
48	61362	90° Long Elbow	9/16-18 ORB to 9/16-18JIC	3					
49	60058	Bulkhead Nut	3/4-16JIC	1					
50	61626	Hose Assembly	1/2ID - 27.9 Long	1					
51	61627	Hose Assembly	1/2ID - 27 1/4 Long	1					
52	61700	Hose Assembly	5/16ID - 36 Long	1					
53	61701	Hose Assembly	5/16ID - 32 Long	1					
54	60070	Hose Assembly	3/8ID - 15 3/8 Long	1					
55	61896	Hose Barb - Male	1" NPT to 1" ID Hose	1					
56	100007	Hose Clamp		2					
57	100069	Male Connector	3/4-16 ORB to 3/4-16JIC	2					
58	60061	Male Connector	9/16-18JIC to 1/2NPT	1					
59	82056	90° Elbow	9/16-18 ORB to 3/4-16JIC	3					
60	61629	Male Connector	9/16-18 ORB to 3/4-16JIC	1					
63	61892	Pump	(Barnes)	1					
65	80131	90° Elbow	3/4-16 ORB to 3/4-16JIC	1					
66	61682	Check Valve	1/2 NPT	1					
67	61688	Oil Cooler		1					
#	62162	Kit - Test Pressure HS		1					
#	61412	Hose Clamp		1					
#	100234	HFHSL Screw	5/16-18NC x 3/4 Gr. 5	1					
#	100237	HFHSL Nut	5/16-18NC	1					
#		NOT SHOWN							

HYDRAULIC DIAGRAM MODEL EXP 69

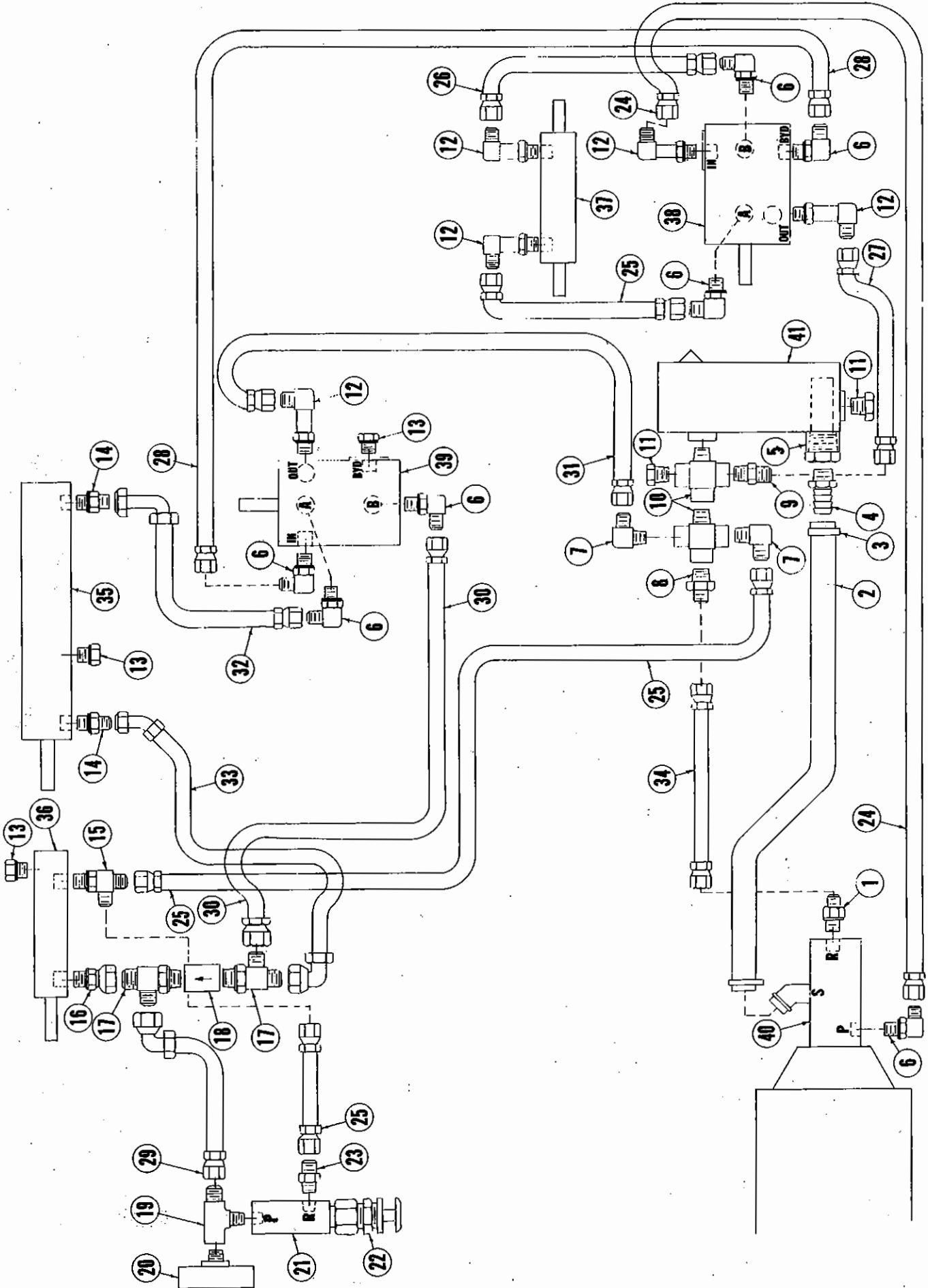

1 PHASE WIRING DIAGRAM MODELS MC59, MC59HS 61554

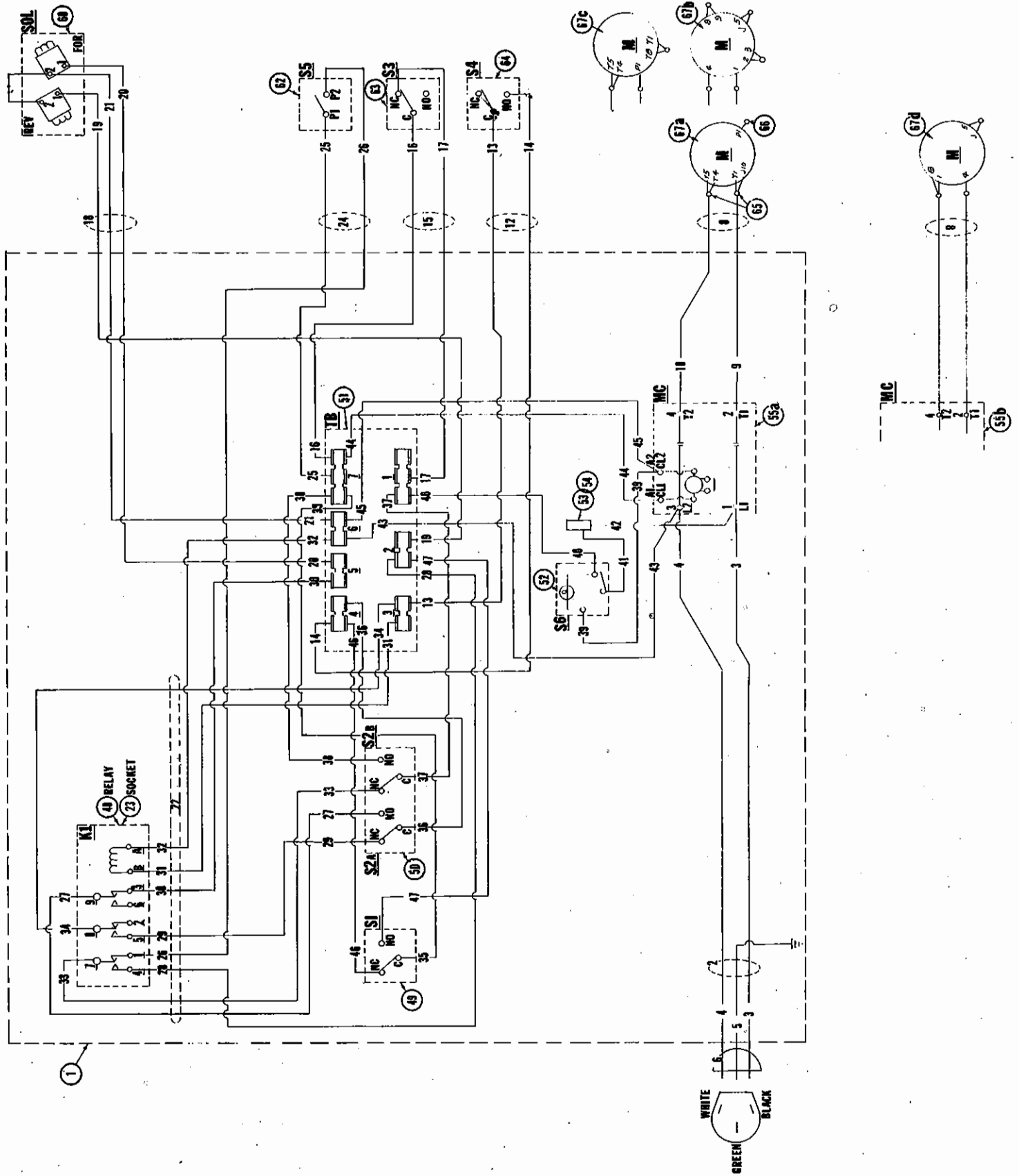

**1 PHASE WIRING - MODELS MC59 - MC59HS
AUTOMATIC MOTOR CUT-OFF -- 220V CONTROL CIRCUIT**

Code	Part Number	Part Name	Quantity		
			MC59	MC59 HS	
1	61319	Control Box Assembly Includes:	1		
	61641	Control Box Assembly Includes:		1	
2	60316	Cord Assembly (Power) 10/3 S0 230 Long	1	1	
3		Black MC-L1 1Ø Plug			
4		White MC-L2 1Ø Plug			
5		Green Ground			
6		Plug #60320 1Ø			
8	60907	Cord (Motor) 10/2 S0 30 Long	1	1	
9		Black MC-T1 Motor			
10		White MC-T2 Motor			
12	60908	Cord Assembly 18/2 SJO 24 Long	1	1	
13		White S4-C TB-3			
14		Black S4-NO TB-4			
15	60909	Cord Assembly 18/2 SJO 36 Long	1	1	
16		White S3-c TB-7			
17		Black S3-NC TB-1			
18	62235	Cord Assembly 18/3 SJO 60 Long			
19		White SOL-R1 TB-2			
20		Black SOL-F1 TB-5			
21		Red SOL-F2 TB-6			
22	61772	Socket w/Wire Assembly	1	1	
23		Socket #61773 K1			
24		Cord Assembly #61774 18/2 SJO 60 Long			
25		Black TB-7 S5-P1			
26		White K1-1 S5-P2			
27		Wire Assembly #61776 K1-9 S2A-NO			
28		Wire Assembly #61775 K1-4 TB-2			
29		Wire Assembly #61776 K1-5 S2A-NC			
30		Wire Assembly #61775 K1-3 TB-5			
31		Wire Assembly #61775 K1-B TB-3			
32		Wire Assembly #61775 K1-A TB-6			
33		Wire Assembly #61776 K1-7 S2B-NC			
34		Wire Assembly #61775 K1-8 TB-3			
35	60391	Wire Assembly 18 Ga Orange 8" S1-c TB-7	1	1	
36	60388	Wire Assembly 18 Ga Orange 12" S2A-C TB-4	1	1	
37	60388	Wire Assembly 18 Ga Orange 12" S2B-C TB-1	1	1	
38	60388	Wire Assembly 18 Ga Orange 12" S2B-NO TB-7	1	1	
39	60643	Wire Assembly 18 Ga Orange 8" S6 MC-CL2	1	1	
40	60360	Wire Assembly 18 Ga Orange 12" S6 TB-1	1	1	
41	61367	Wire Assembly 18 Ga Orange 8" S6 Fuse	1	1	
42	60643	Wire Assembly 18 Ga Orange 8" MC-11 Fuse	1	1	
43	60396	Wire Assembly 18 Ga Orange 12" MC-12 TB-6	1	1	
44	60396	Wire Assembly 18 Ga Orange 12" MC-CL1 TB-7	1	1	
45	60396	Wire Assembly 18 Ga Orange 12" MC-CL2 TB-6	1	1	
46	60391	Wire Assembly 18 Ga Orange 8" S1-NC TB-4	1	1	
47	60391	Wire Assembly 18 Ga Orange 8" S1-NO TB-2	1	1	
48	61770	Relay K1	1	1	
49	60308	Micro Switch - Reverse Cont. S1	1	1	
50	60309	Micro Switch - Forward S2A-S2B	1	1	
51	60397	Terminal Board Structure TB	1	1	
52	61322	Power Switch - Front w/Light S6	1	1	
53	61324	Fuse Holder	1	1	
54	61325	Fuse (1 AMP)	1	1	
55a	61888	Motor Contactor - 4 Hp 230v MC	1		
55b	62254	Motor Contactor - 7 1/2 Hp 230v MC		1	
60	61950	Control Valve - Solenoid (Directional) SOL	1	1	
62	60423	Swager Switch S5	1	1	
63	60440	Limit Control Switch S3	1	1	
64	60091	Depth Control Switch (Push Button) S4	1	1	
65	60337	Closed End Splice Motor Leads	2	2	
66	61127	Wire Connector Motor	1		
67	62244	Motor 1Ø - 60 Hz - 1750 Rpm 4 Hp	1		
67	62252	Motor 1Ø - 60 Hz - 1750 Rpm 7 1/2 Hp		1	

3 PHASE WIRING DIAGRAM MODELS MC59, MC59HS

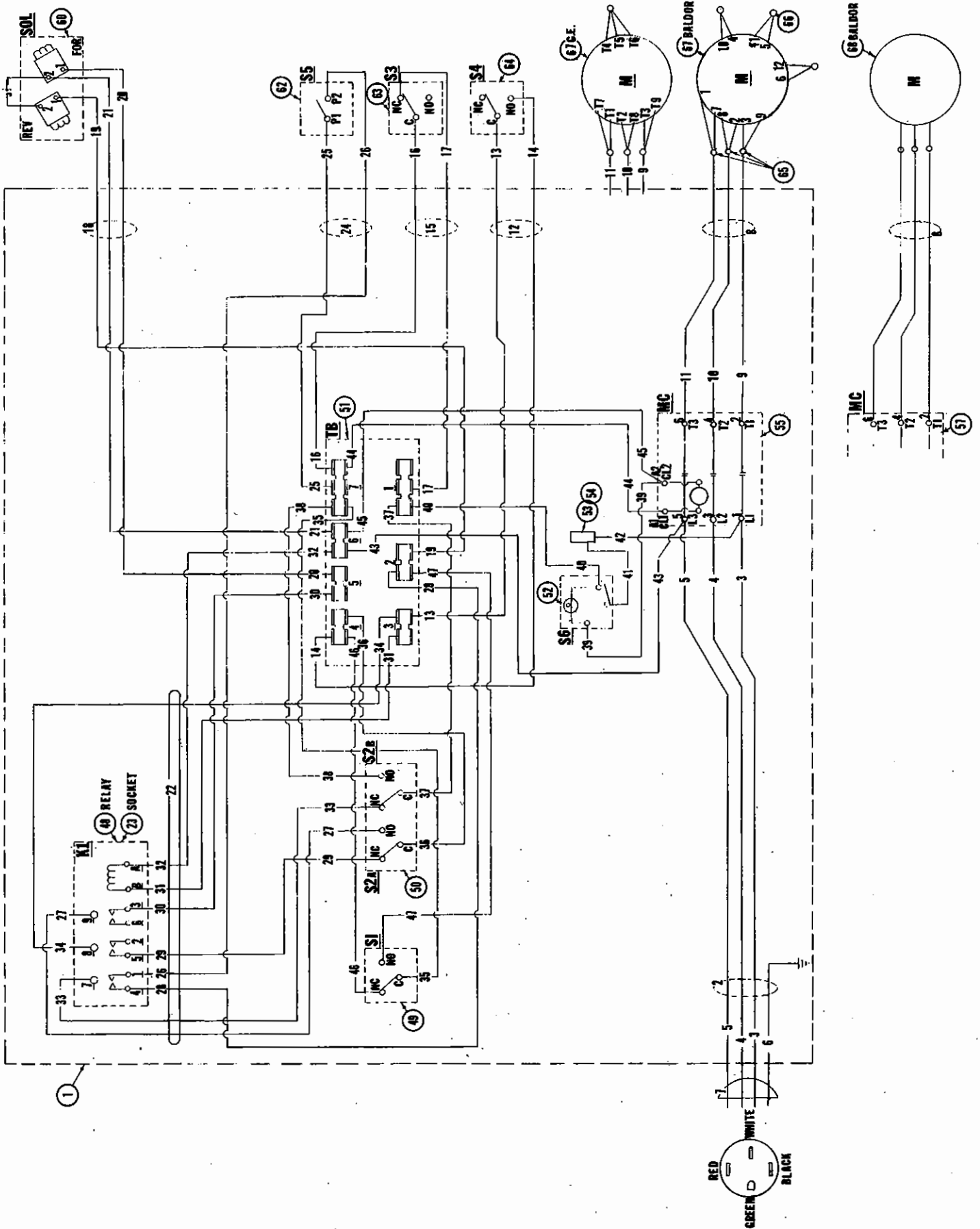

**3 PHASE WIRING - MODELS MC59 - MC59HS
AUTOMATIC MOTOR CUT-OFF -- 220V CONTROL CIRCUIT**

Code	Part Number	Part Name	Quantity		
			MC59	MC59 HS	
1	61284	Control Box Assembly Includes:	1		
1	61673	Control Box Assembly Includes:		1	
2	60624	Cord Assembly (Power) 12/4SO 230 Long	1	1	
3		Black MC-L1 3Ø Plug			
4		White MC-L2 3Ø Plug			
5		Red MC-L3 3Ø Plug			
6		Green Ground			
7		Plug #60592 3Ø			
8	61193	Cord (Motor) 10/3 SO 30 Long	1	1	
9		Black MC-T1 Motor			
10		White MC-T2 Motor			
11		Green MC-T3 Motor			
12	60908	Cord Assembly 18/2SJ0 24 Long	1	1	
13		White S4-C TB-3			
14		Black S4-NO TB-4			
15	60909	Cord Assembly 18/2SJ0 36 Long	1	1	
16		White S3-C TB-7			
17		Black S3-NC TB-1			
18	62235	Cord Assembly 18/3SJ0 60 Long	1	1	
19		White SOL-R1 TB-2			
20		Black SOL-F1 TB-5			
21		Red SOL-F2 TB-6			
22	61772	Socket w/Wire Assembly	1	1	
23		Socket #61773 K1			
24		Cord Assembly #61774 18/2SJ0 60 Long			
25		Black TB-7 S5-P1			
26		White K1-1 S5-P2			
27		Wire Assembly #61776 K1-9 S2A-NO			
28		Wire Assembly #61775 K1-4 TB-2			
29		Wire Assembly #61776 K1-5 S2A-NC			
30		Wire Assembly #61775 K1-3 TB-5			
31		Wire Assembly #61775 K1-B TB-3			
32		Wire Assembly #61775 K1-A TB-6			
33		Wire Assembly #61776 K1-7 S2B-NC			
34		Wire Assembly #61775 K1-8 TB-3			
35	60391	Wire Assembly 18 Ga. Orange 8" S1-C TB-7	1	1	
36	60388	Wire Assembly 18 Ga. Orange 12" S2A-C TB-4	1	1	
37	60388	Wire Assembly 18 Ga. Orange 12" S2B-C TB-7	1	1	
38	60388	Wire Assembly 18 Ga. Orange 12" S2B-NO TB-7	1	1	
39	60643	Wire Assembly 18 Ga. Orange 8" S6 MC-CL2	1	1	
40	60360	Wire Assembly 18 Ga. Orange 12" S6 TB-1	1	1	
41	61367	Wire Assembly 18 Ga. Orange 8" S6 Fuse	1	1	
42	60643	Wire Assembly 18 Ga. Orange 8" MC-L1 Fuse	1	1	
43	60396	Wire Assembly 18 Ga. Orange 12" MC-L3 TB-6	1	1	
44	60396	Wire Assembly 18 Ga. Orange 12" MC-CL1 TB-7	1	1	
45	60396	Wire Assembly 18 Ga. Orange 12" MC-CL2 TB-6	1	1	
46	60391	Wire Assembly 18 Ga. Orange 8" S1-NC TB-4	1	1	
47	60391	Wire Assembly 18 Ga. Orange 8" S1-NO TB-2	1	1	
48	61770	Relay K1	1	1	
49	60308	Micro Switch-Reverse Cont. S1	1	1	
50	60309	Micro Switch-Forward S2A-S2B	1	1	
51	60397	Terminal Board Structure TB	1	1	
52	61322	Power Switch-Front w/Light S6	1	1	
53	61324	Fuse Holder	1	1	
54	61325	Fuse (1 AMP)	1	1	
55	61888	Motor Contactor - 4 Hp 230v MC	1		
57	62254	Motor Contactor - 7 1/2 Hp 230v MC		1	
60	61950	Control Valve - Solenoid (Directional) SOL	1	1	
62	60423	Swager Switch S5	1	1	
63	60440	Limit Control Switch S3	1	1	
64	60091	Depth Control Switch (Push Button) S4	1	1	
65	60337	Closed End Splice (Qty. 3) Motor Leads	3	3	
66	61127	Wire Connector Motor	1	1	
67	62251	Motor - 3Ø - 60 Hz. 1750 RPM - 4 Hp. M	1		
68	62257	Motor - 3Ø - 60 Hz. 1750 RPM - 7 1/2 Hp.		1	

1 PHASE WIRING DIAGRAM EXP 69

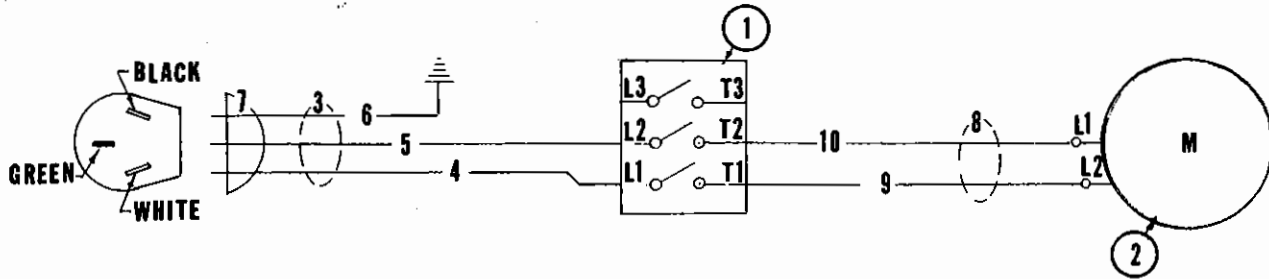

Code	Part Number	Part Name	Quantity		
			EXP	69	
		From TO			
1	62262	Manual Starting Switch	1		
2	62244	Motor 1Ø - 60 Hz. 4 Hp.	1		
3	61915	Power Cord Assembly 10/3 SØ - 230"	1		
4		White L1 Plug			
5		Black L2 Plug			
6		Green Ground Plug			
7	60320	Plug 1Ø			
8	62034	Motor Cord Assembly 10/2 SØ 30"	1		
9		White T1 M-L2			
10		Black T2 M-L1			
#	61103	Strain Relief Bushing (In Switch Enclosure)	2		
#	61104	Conduit Lock Nut 3/4 NPT	2		

3 PHASE WIRING DIAGRAM EXP 69

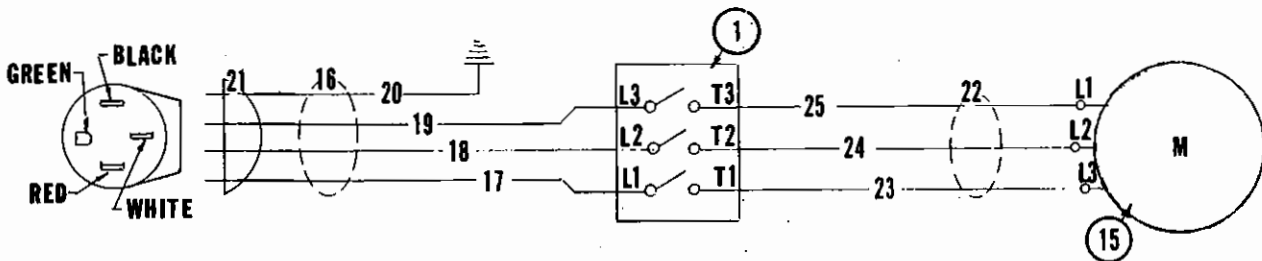

Code	Part Number	Part Name	Quantity		
			EXP	69	
		From TO			
1	62262	Manual Starting Switch	1		
15	62251	Motor 3Ø - 60 Hz - 4 Hp.	1		
16	62032	Power Cord Assembly 12/4 SØ 230"	1		
17		Black L1 Plug			
18		White L2 Plug			
19		Red L3 Plug			
20		Green Ground Plug			
21	60592	Plug 3Ø	1		
22	62033	Motor Cord Assembly 10/3 SØ 30"	1		
23		Black T1 M-L3			
24		White T2 M-L2			
25		Red T3 M-L1			
#	61103	Strain Relief Bushing (In Switch Enclosure)	2		
#	61104	Conduit Lock Nut 3/4 NPT	2		

CONTROL BOX FOR MODELS WITH AUTOMATIC MOTOR CUT-OFF

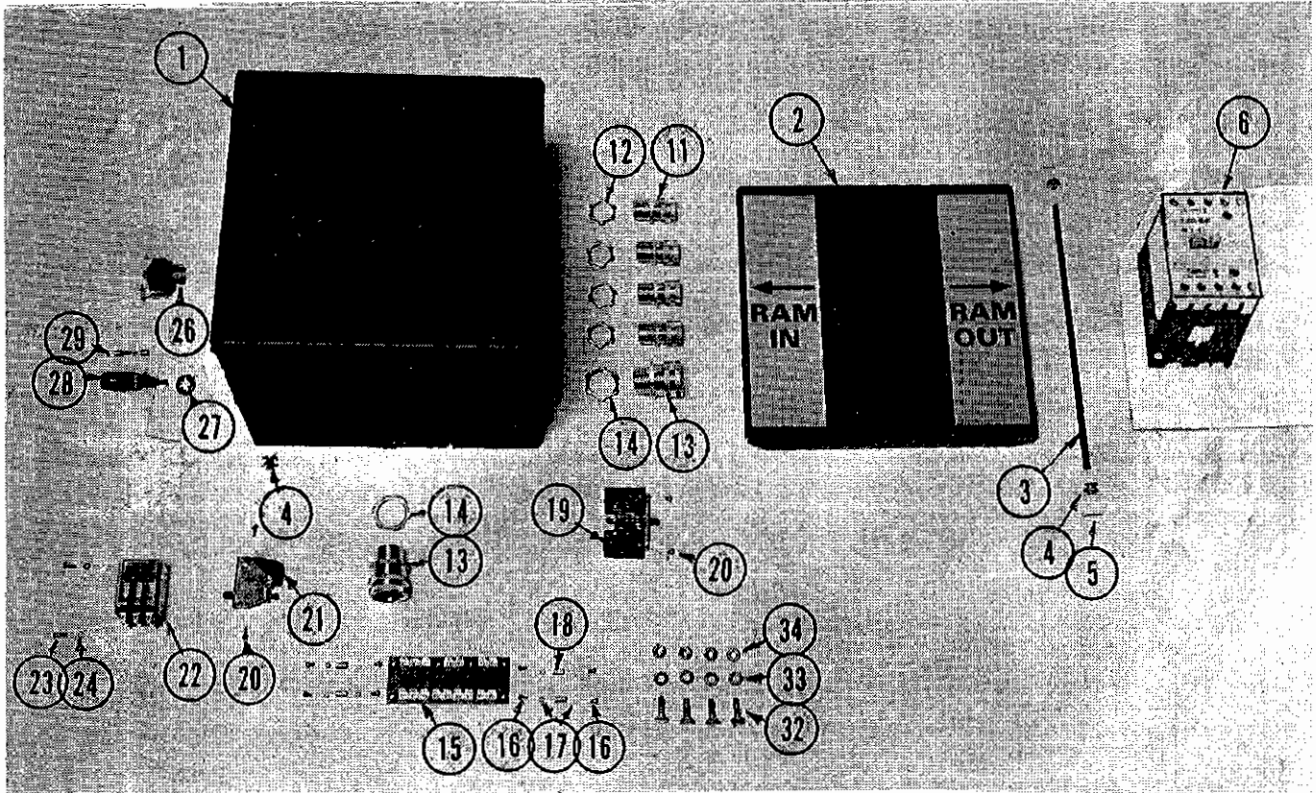

Code	Part Number	Part Name	Quantity	
			MC59	MS9 HS
-	61319	Control Box Assembly (Consists Of Codes 1 To 32)	1	
-	61641	Control Box Assembly (Consists Of Codes 1 To 32)		1
1	61370	Control Box Structure	1	1
2	60285	Cover Assembly	1	1
3	60215	Pin - Cover	1	1
4	60260	Bushing w/Nut	3	3
5	100185	Cotter Pin 1/16 x 1/2	2	2
6	61888	Motor Contactor 4 Hp. International	1	
6	62254	Motor Contactor 7 1/2 Hp. International		1
11	61101	Relief Bushing	4	4
12	61102	Conduit Lock Nut 1/2 NPT	4	4
13	61103	Relief Bushing	2	2
14	61104	Conduit Lock Nut 3/4 NPT	2	2
15	60397	Terminal Board Assembly	1	1
16	60261	Round Head Machine Screw #4-40 NC x 1/4	8	8
17	60268	Lock Washer #4	8	8
18	60277	Stand-Off	4	4
19	60309	Micro-Switch (Double)	1	1
20	60262	Round Head Machine Screw #6-32NC x 3/16	4	4
21	60308	Micro-Switch	1	1
22	61770	Relay	1	1
#	61771	Spring - Relay Hold Down	1	1
#	61769	Stand-Off (Relay)	2	2
23	100103	Round Head Machine Screw #8-32 NC x 7/16	4	4
24	100171	Lock Washer #8	4	4
26	61322	Front Power Switch w/Light	1	1
27	61384	Lock Washer - Internal Tooth 1/2	1	1
28	61324	Fuse Holder	1	1
29	61325	Fuse 1 Amp	1	1
#	61375	Decal "CAUTION"	1	1
#	61433	Decal "REPLACEMENT FUSE"	1	1
#	-	Wiring In Box (See Wiring Diagram)		
32	100210	Hex Screw (Box To Frame) 1/4-20 NC x 1 Gr. 5	4	4
33	100134	Lock Washer (Box To Frame) 1/4	4	4
34	100131	Hex Nut (Box To Frame) 1/4 - 20 NC	8	8
#	61843	Micro Switch Spring (Replacement Only - 60309)		
#	61974	Micro Switch Spring (Replacement Only - 60308)		

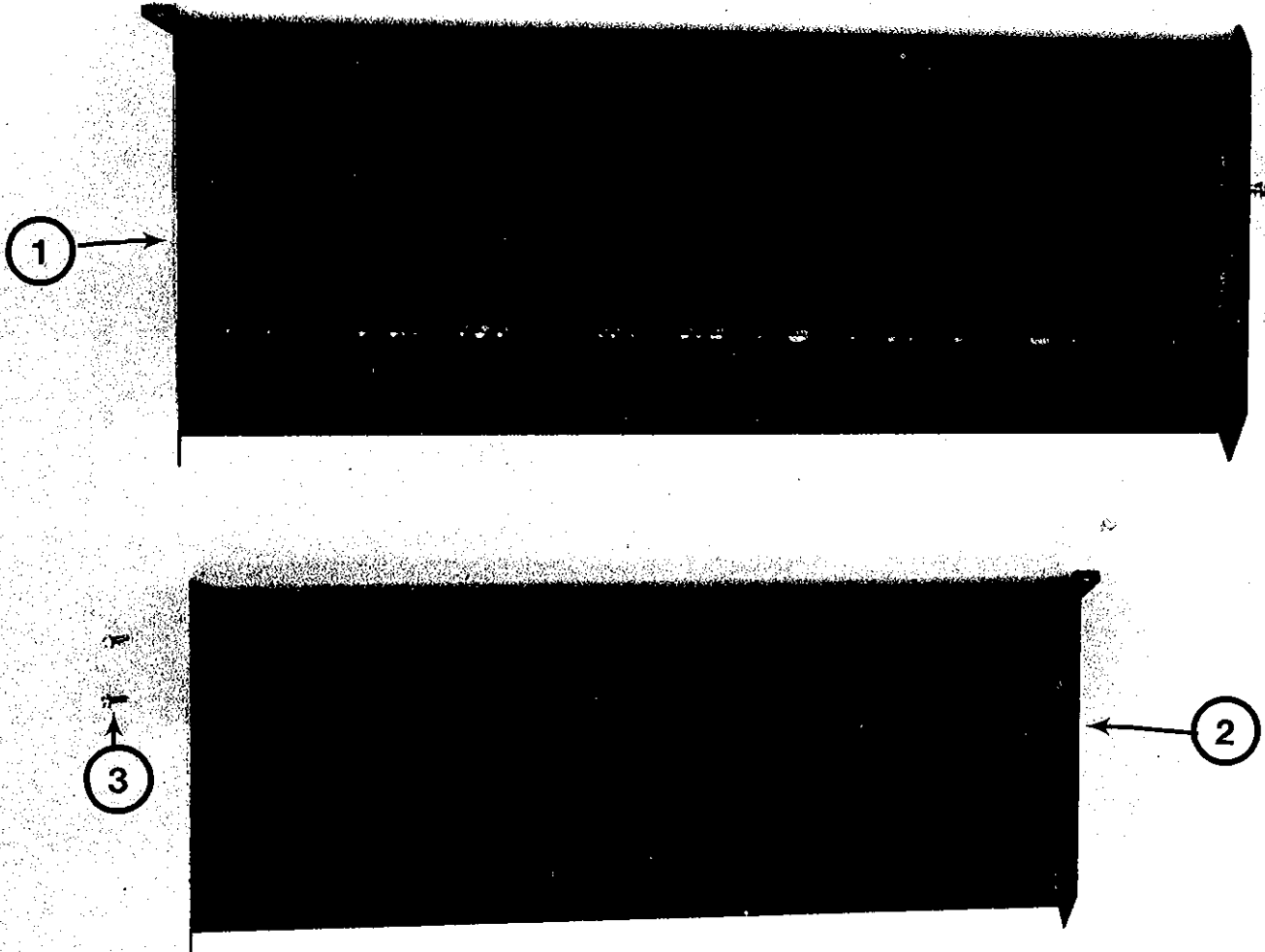

CODE	PART NUMBER	PART NAME	QUANTITY		
			MC59		
1	62500	Die Support Structure	1		
2	62501	Die Support Structure w/Tray	1		
3	100076	Screw - Thread Cutting 5/16-18NC x 3/4	6		

SHORT DIE TRAYS

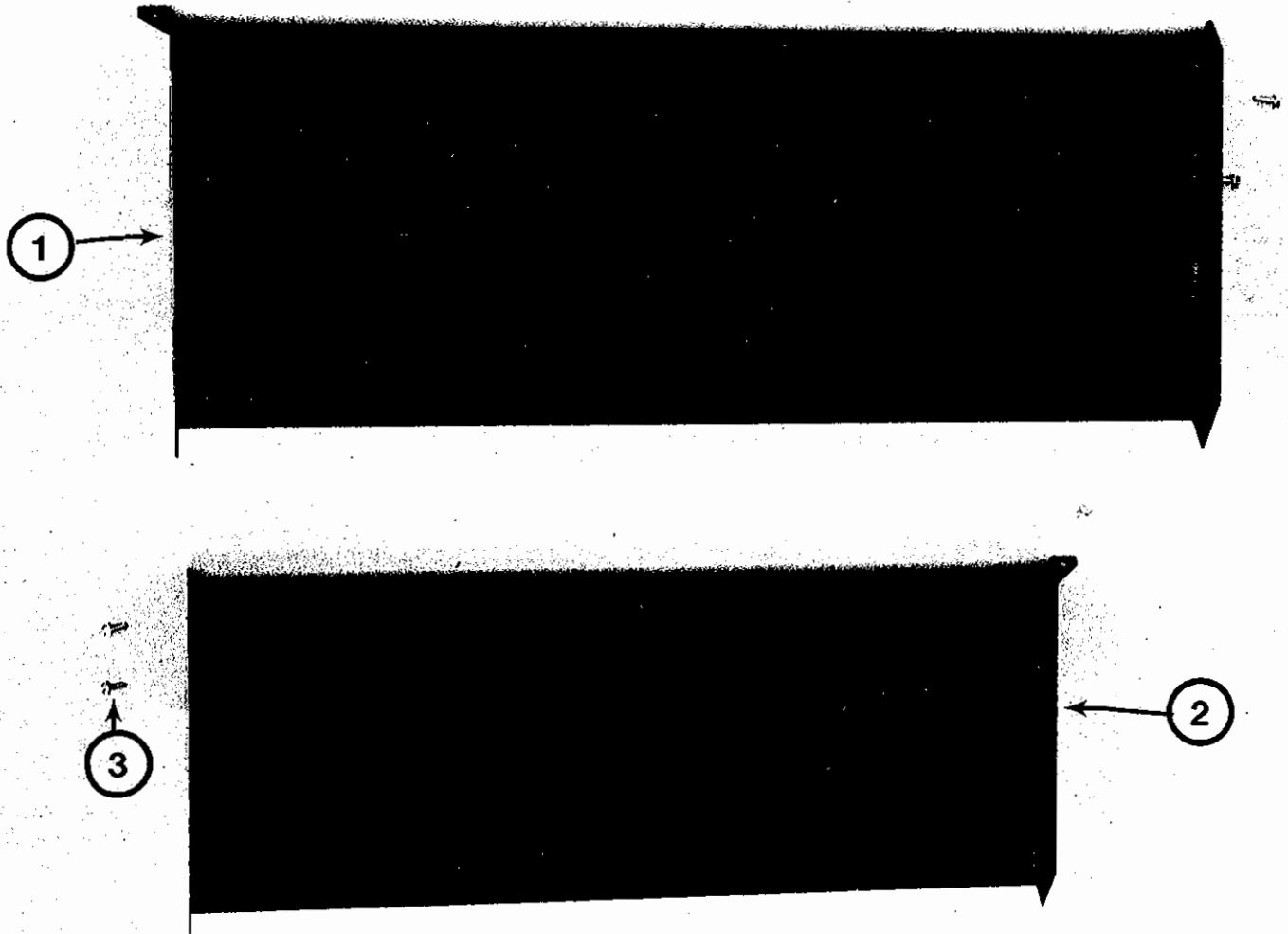

CODE	PART NUMBER	PART NAME	QUANTITY		
			MC59		
1	62483	Die Support Structure	1		
2	62484	Die Support Structure w/Tray	1		
3	100076	Screw - Thread Cutting 5/16-18NC x 3/4	6		

BENDING DIES

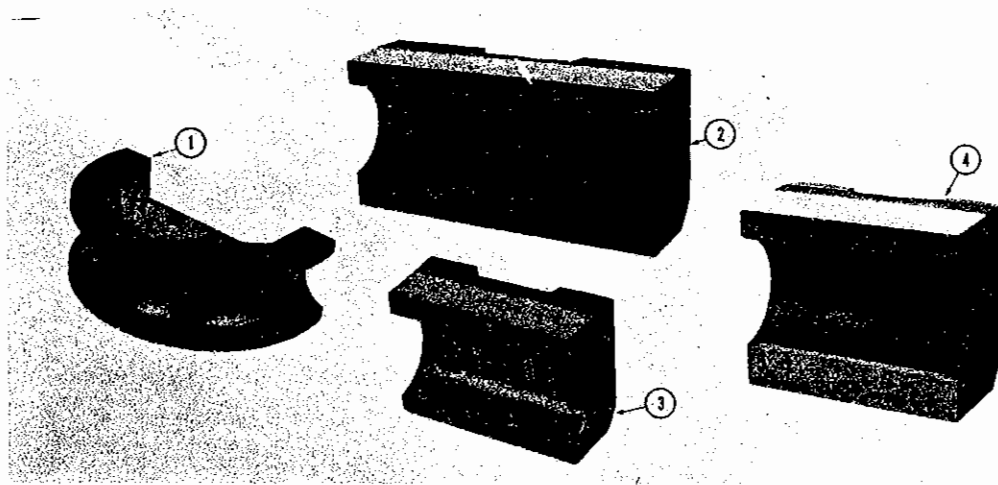

Code	Part Number	Part Name	QTY.
1	60876	Radius Die, 114-3	1
1	60877	Radius Die, 138-3	1
1	61230	Radius Die, 138-4	1
1	60221	Radius Die, 112-3	1
1	60222	Radius Die, 112-4	1
1	61044	Radius Die, 158-3	1
1	60878	Radius Die, 158-4	1
1	61083	Radius Die, 158-5	1
1	60225	Radius Die, 134-3	1
1	60226	Radius Die, 134-4	1
1	60227	Radius Die, 134-5	1
1	60230	Radius Die, 178-3	1
1	60231	Radius Die, 178-4	1
1	60232	Radius Die, 178-5	1
1	60235	Radius Die, 200-3	1
1	60236	Radius Die, 200-4	1
1	60237	Radius Die, 200-5	1
1	61084	Radius Die, 218-3	1
1	61085	Radius Die, 218-4	1
1	61062	Radius Die, 218-5	1
1	60240	Radius Die, 214-3	1
1	60241	Radius Die, 214-4	1
1	60242	Radius Die, 214-5	1
1	61114	Radius Die, 238-4	1
1	61115	Radius Die, 238-5	1
1	60245	Radius Die, 212-4	1
1	60246	Radius Die, 212-5	1
1	61121	Radius Die, 234-5	1
1	61020	Radius Die, 300-5	1

Code	Part Number	Part Name	QTY.
2	61107	Back Shoe, 114-1	2
2	61109	Back Shoe, 138-1	2
2	61000	Back Shoe, 112-1	2
2	61111	Back Shoe, 158-1	2
2	61001	Back Shoe, 134-1	2
2	61002	Back Shoe, 178-1	2
2	61003	Back Shoe, 200-1	2
2	61086	Back Shoe, 218-1	2
2	61004	Back Shoe, 214-1	2
2	61116	Back Shoe, 238-1	2
2	61005	Back Shoe, 212-1	2
2	61122	Back Shoe, 234-1	2
2	61006	Back Shoe, 300-1	2
3	61108	Half Shoe, 114-H	1
3	61110	Half Shoe, 138-H	1
3	61014	Half Shoe, 112-H	1
3	61112	Half Shoe, 158-H	1
3	61015	Half Shoe, 134-H	1
3	61016	Half Shoe, 178-H	1
3	61017	Half Shoe, 200-H	1
3	61087	Half Shoe, 218-H	1
3	61018	Half Shoe, 214-H	1
3	61117	Half Shoe, 238-H	1
3	61019	Half Shoe, 212-H	1
3	61123	Half Shoe, 234-H	1
4	61879	Three Quarter Shoe, 114-0	1
4	61880	Three Quarter Shoe, 138-0	1
4	61008	Three Quarter Shoe, 112-0	1
4	61045	Three Quarter Shoe, 158-0	1
4	61009	Three Quarter Shoe, 134-0	1
4	61010	Three Quarter Shoe, 178-0	1
4	61011	Three Quarter Shoe, 200-0	1
4	61783	Three Quarter Shoe, 218-0	1
4	61012	Three Quarter Shoe, 214-0	1
4	61784	Three Quarter Shoe, 238-0	1
4	61013	Three Quarter Shoe, 212-0	1
4	62011	Three Quarter Shoe, 234-0	1
4	62449	Three Quarter Shoe, 300-0	1

SEGMENTED EXPANDERS AND FLARES

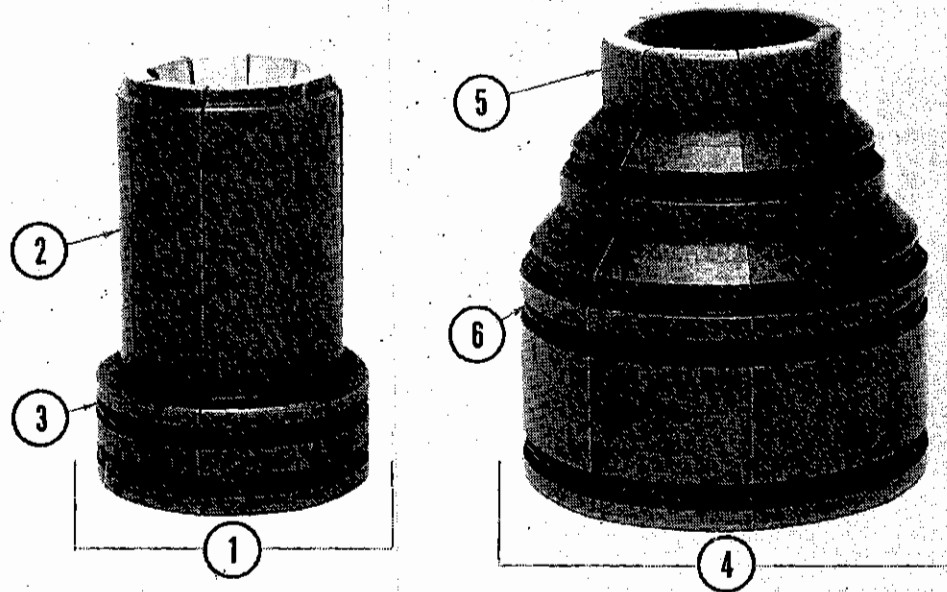

CODE	PART NUMBER	PART NAME	QUANTITY		
			BP79		
*1	61046	Segmented Expander, 1-1/4 and 1-3/8	1		
2	61060	Segment (6)			
3	60364	O'Ring (2)			
1	61967	Segmented Expander, 1-1/2 and 1-5/8	1		
2	61968	Segment (8)			
3	60364	O'Ring (2)			
1	61548	Segmented Expander, 1-3/4 Thru 2	1		
2	61758	Segment (8)			
3	60364	O'Ring (2)			
1	61549	Segmented Expander, 2-1/8 Thru 2-1/2	1		
2	61777	Segment (8)			
3	60366	O'Ring (2)			
1	61550	Segmented Expander, 2-5/8 Thru 3	1		
2	61759	Segment (8)			
3	60258	O'Ring (2)			
4	61136	Segmented 45 Degree Flare, 1-1/2	1		
5	61551	Segment (6)			
6	60256	O'Ring (2)			
4	61542	Segmented 45 Degree Flare, 1-3/4 & 1-7/8 - 2-1/4 & 2-3/8	1		
5	61753	Segment (8)			
6	60256	O'Ring (2)			
4	61778	Segmented 45 Degree Flare, 2 and 2-1/2	1		
5	61781	Segment (8)			
6	60356	O'Ring (2)			
4	60447	Segmented 45 Degree Flare, 3	1		
5	60898	Segment (8)			
6	60363	O'Ring (2)			
#	60366	O'Ring (1)			
1	62452	Segmented Expander, 3-1/8 Thru 3-1/2	1		
2	62489	Segment (8)			
3	62490	O'Ring (2)			
3	62491	O'Ring (1)			
1	62453	Segmented Expander, 3-5/8 Thru 4	1		
2	62492	Segment (8)			
3	62493	O'Ring (2)			
3	62494	O'Ring (1)			
*		Requires Small Arbor #61261			
#		Not Shown			

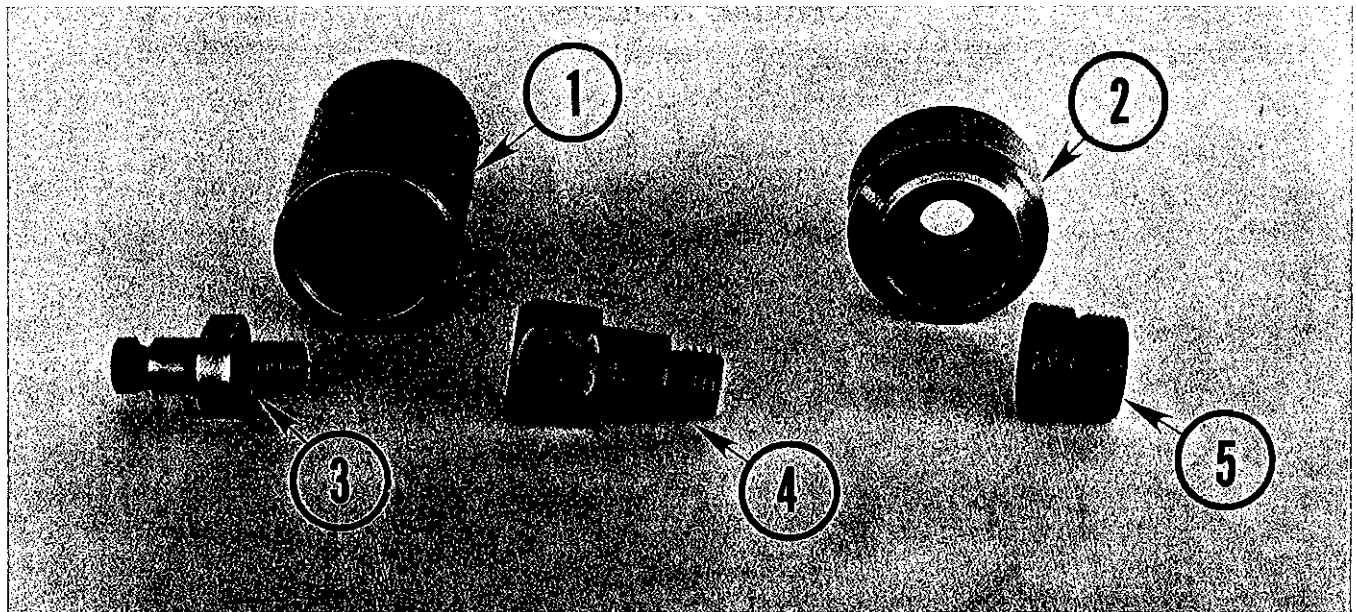

Code	Part Number	Part Name	Quantity		
-	62160	1 5/8 Reducer Tool Assembly	1		
1		1 - 62161 Reducer Tool 1 5/8			
5		1 - 61248 Adapter Assembly Includes:			
		1 - 61311 Hardened Pin 1/4 x 7/8			
-	62212	1 3/4 Reducer Tool Assembly	1		
1		1 - 62211 Reducer Tool 1 3/4			
5		1 - 61248 Adapter Assembly Includes:			
		1 - 61311 Hardened Pin 1/4 x 7/8			
-	61254	1 7/8 Reducer Tool Assembly	1		
1		1 - 61255 Reducer Tool 1 7/8			
5		1 - 61248 Adapter Assembly Includes:			
		1 - 61311 Hardened Pin 1/4 x 7/8			
-	61252	2 Reducer Tool Assembly	1		
1		1 - 61253 Reducer Tool 2			
5		1 - 61248 Adapter Assembly Includes:			
		1 - 61311 Hardened Pin 1/4 x 7/8			
-	61250	2 1/4 Reducer Tool Assembly	1		
1		1 - 61251 Reducer Tool 2 1/4			
5		1 - 61248 Adapter Assembly Includes:			
		1 - 61311 Hardened Pin 1/4 x 7/8			
-	62233	2 1/2 Reducer Tool Assembly	1		
1		1 - 62230 2 1/2 Reducer Tool			
5		1 - 61248 Adapter Assembly Includes:			
		1 - 61311 Hardened Pin 1/4 x 7/8			
-	62232	2 3/4 Reducer Tool Assembly	1		
1		1 - 62228 Reducer Tool 2 3/4			
5		1 - 61248 Adapter Assembly Includes:			
		1 - 61311 Hardened Pin 1/4 x 7/8			
-	61258	1 1/2 & 2 Super Flange Tool Assembly Includes:	1		
2		1 - 61259 Super Flange Tool 1 1/2 & 2			
4		1 - 61256 Flange Extension Assembly Includes:			
		1 - 61311 Hardened Pin 1/4 x 7/8			
-	61792	1 3/4 & 2 1/4 Super Flange Tool Assembly	1		
2		1 - 61794 Super Flange Tool 1 3/4 & 2 1/4			
4		1 - 61256 Flange Extension Assembly Includes:			
		1 - 61311 Hardened Pin 1/4 x 7/8			
3	61247	Adapter (Use w/All Above Parts)	1		

